

VT Series

High Sensitivity & High Speed TDI Line Scan Cameras

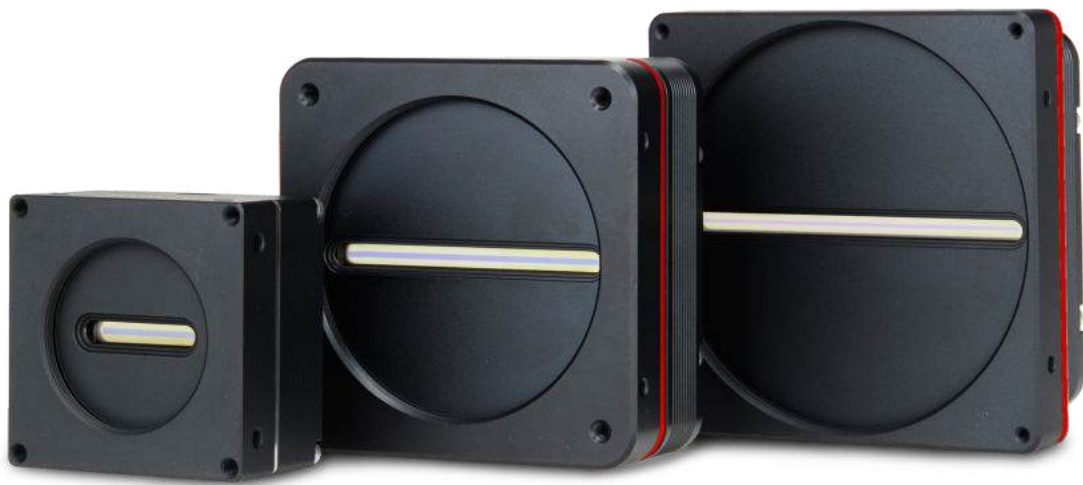

VTDI

- Next Generation Hybrid TDI Line Scan Technology
- Up to 250 kHz at 9k Resolution and 100 kHz at 23k Resolution
- Greater Sensitivity at Faster Speed with Very Low Noise

CoaPress[®]

VIEWWORKS

vision.viewworks.com

VT Series – High Sensitivity TDI Line Scan Cameras

Overview

VT series, Vieworks' Time Delayed Integration line scan cameras, is designed for applications where faster line rates and higher sensitivity are crucial.

Vieworks' advanced TDI line scan technology based on the outstanding hybrid imaging sensors allows image captures as fast as 250 kHz line rates with up to 128× higher sensitivity using the M72 mount based VT-9K7X camera.

Even superior resolution and sensitivity, up to 23360 pixel resolution at 100 kHz line rate and 256× greater sensitivity can be achieved using the M95 mount based VT-23K3.5X camera.

A diverse lineup of VT TDI line scan cameras is now available at reasonable prices to meet various system design requirements including resolution, line rate, sensitivity and lens mount (M72/M95) specifications.

VT series is available with the latest CoaXPress interface standard to meet application-specific requirements.

Featured with high speed and high sensitivity, this brand new technology is ideal for demanding applications such as flat panel display inspection, wafer inspection, printed circuit board inspection, and high-performance document scanning.

Main Features

- 9k / 12k / 16k / 18k / 23k TDI Line Scan Cameras
- Bidirectional Operations with up to 256 TDI stages
- CoaXPress Interface
- Anti-blooming
- Advanced PRNU and DSNU Correction
- Area Scan Mode for Camera Alignment

Applications

- Flat Panel Display Inspection
- Printed Circuit Board Inspection
- Wafer Inspection
- High Performance Document Scanning



VT Series – High Sensitivity TDI Line Scan Cameras

M95 Mount based VT Series Specifications



Model	VT-16K5X-S140A-256	VT-23K3.5X-S100A-256
Resolution (H × V)	16384 × 256	23360 × 256
Pixel Size	5.0 μm × 5.0 μm	3.5 μm × 3.5 μm
Interface	CoaXPRESS (CXP-6, 4 CH)	
Max. Line Rate	140 kHz (@ROI 16384)	100 kHz (@ROI 23360)
Max. Line Rate (2 × 2 Binning)	120 kHz	100 kHz
Min. Line Rate	1 kHz	
Pixel Data Format	8 / 10 / 12 bit	
TDI Stage	64 / 128 / 192 / 256	
Trigger Mode	Free-Run, Timed, Trigger Width	
Throughput	2.29 Gpix/s	2.34 Gpix/s
Gamma Correction	User Defined Lookup Table (LUT)	
Black Level	-255 ~ 255 at 8 bit	
Gain Control	Analog Gain: 1×, 2×, 3×, 4× / Digital Gain: 1.0× ~ 8.0×	
Lens Mount	M95 × 1	
Dimension / Weight	100 mm × 100 mm × 43 mm / 608 g	
Temperature	Ambient Operating: 0°C ~ 40°C (Housing: 10°C ~ 50°C), Storage: -40°C ~ 70°C	
Power	10 ~ 30 V DC	
Power Dissipation	Typ. 17.0 W	Typ. 21.0 W
API SDK	Vieworks Imaging Solution 7.X	

Mechanical Dimension in mm

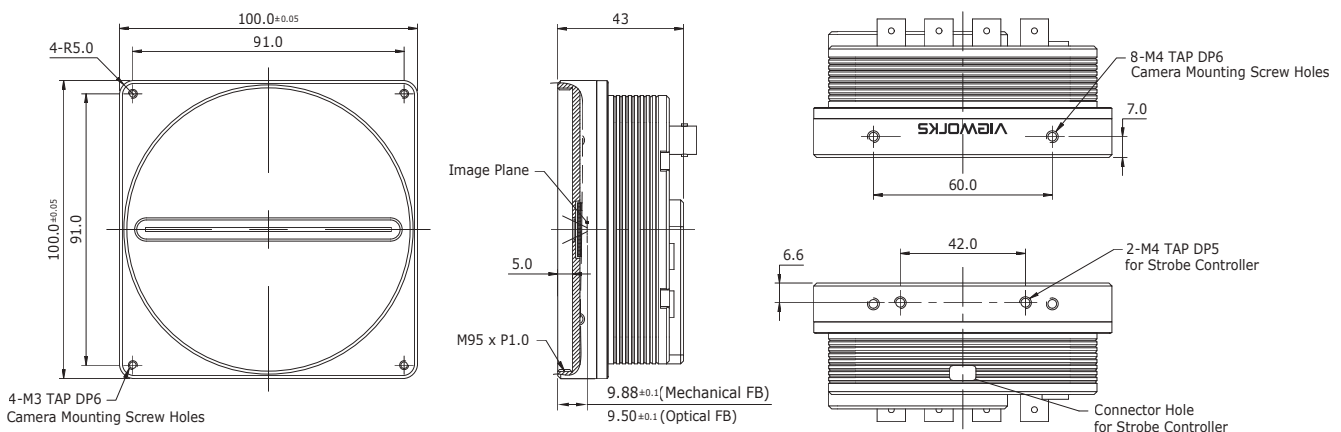

VT Series – High Sensitivity TDI Line Scan Cameras

M72 Mount based VT Series Specifications



Model	VT-9K7X-S250A-128	VT-12K5X-S200A-256	VT-18K3.5X-S140A-256
Resolution (H × V)	8912 × 128	12480 × 256	17824 × 256
Pixel Size	7.0 μm × 7.0 μm	5.0 μm × 5.0 μm	3.5 μm × 3.5 μm
Interface	CoaxPress (CXP-6, 4 CH)		
Max. Line Rate	250 kHz (@ROI 8912)	192 kHz (@ROI 12480)	134 kHz (@ROI 17824)
Max. Line Rate (2 × 2 Binning)	208 kHz	172 kHz	140 kHz
Min. Line Rate	1 kHz		
Pixel Data Format	8 / 10 / 12 bit		
TDI Stage	32 / 64 / 96 / 128	64 / 128 / 192 / 256	
Trigger Mode	Free-Run, Timed, Trigger Width		
Throughput	2.23 Gpix/s	2.40 Gpix/s	2.42 Gpix/s
Gamma Correction	User Defined Lookup Table (LUT)		
Black Level	-255 ~ 255 at 8 bit		
Gain Control	Analog Gain: 1×, 2×, 3×, 4× / Digital Gain: 1.0× ~ 8.0×		
Lens Mount	M72 × 0.75		
Dimension / Weight	90 mm × 90 mm × 43 mm / 500 g		
Temperature	Ambient Operating: 0°C ~ 40°C (Housing: 10°C ~ 50°C), Storage: -40°C ~ 70°C		
Power	10 ~ 30 V DC		
Power Dissipation	Typ. 14.0 W	Typ. 17.0 W	
API SDK	Vieworks Imaging Solution 7.X		

Mechanical Dimension in mm

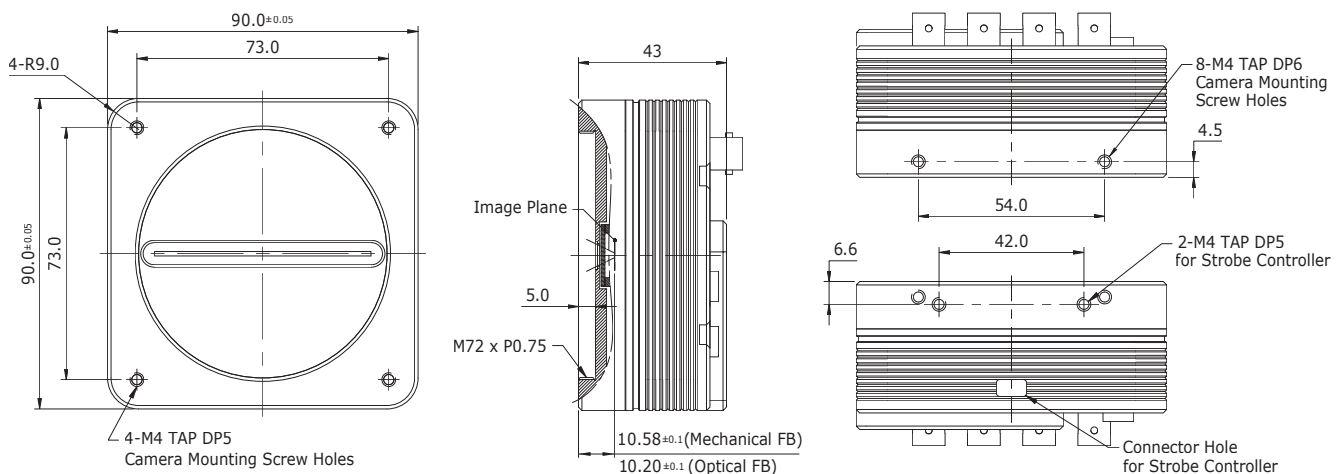

VT Series – High Sensitivity TDI Line Scan Cameras

M72 Mount based VT Series Specifications



Model	VT-9K7X-S120A-128	VT-12K5X-S100A-256	VT-18K3.5X-S80A-256
Resolution (H × V)	8912 × 128	12480 × 256	17824 × 256
Pixel Size	7.0 μm × 7.0 μm	5.0 μm × 5.0 μm	3.5 μm × 3.5 μm
Interface	CoaXPress (CXP-6, 4 CH)		
Max. Line Rate	125 kHz (@ROI 8912)	100 kHz (@ROI 12480)	80 kHz (@ROI 17824)
Max. Line Rate (2 × 2 Binning)	125 kHz	100 kHz	80 kHz
Min. Line Rate	1 kHz		
Pixel Data Format	8 / 10 / 12 bit		
TDI Stage	32 / 64 / 96 / 128	64 / 128 / 192 / 256	
Trigger Mode	Free-Run, Timed, Trigger Width		
Throughput	1.11 Gpix/s	1.25 Gpix/s	1.43 Gpix/s
Gamma Correction	User Defined Lookup Table (LUT)		
Black Level	-255 ~ 255 at 8 bit		
Gain Control	Analog Gain: 1×, 2×, 3×, 4× / Digital Gain: 1.0× ~ 8.0×		
Lens Mount	M72 × 0.75		
Dimension / Weight	90 mm × 90 mm × 38 mm / 500 g		
Temperature	Ambient Operating: 0°C ~ 40°C (Housing: 10°C ~ 50°C), Storage: -40°C ~ 70°C		
Power	10 ~ 30 V DC		
Power Dissipation	Typ. 14.0 W		Typ. 17.0 W
API SDK	Vieworks Imaging Solution 7.X		

Mechanical Dimension in mm

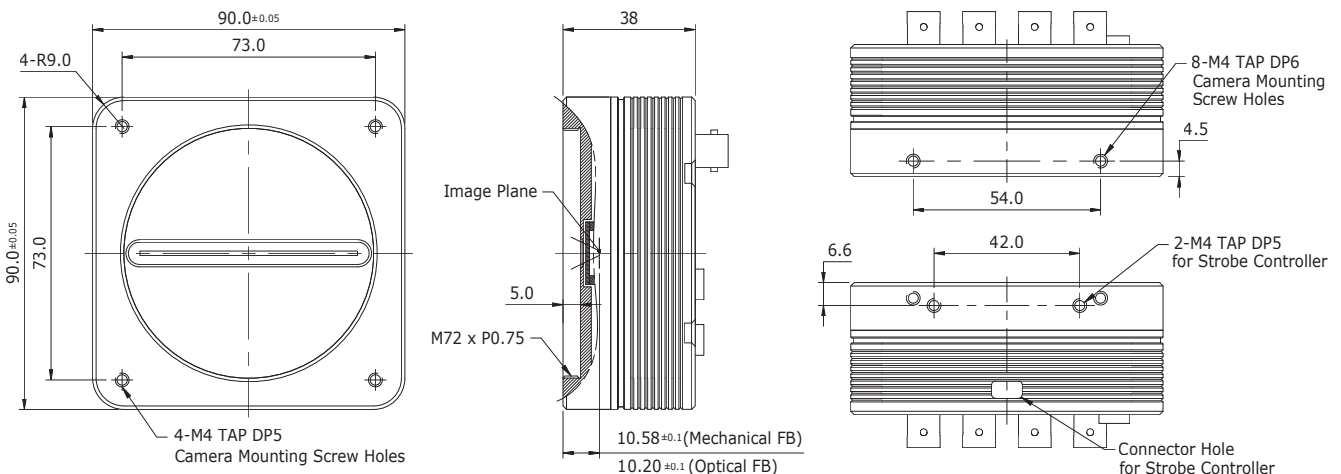

VT Series – High Sensitivity TDI Line Scan Cameras

Specifications

Connector Specification

Power

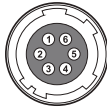

1 2 3: +12V DC, 4 5 6: GND
(HR10A-7R-6PB)

Control

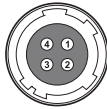

1: Trigger IN, 2: Direction IN
3: DC Ground, 4: Strobe OUT+
(HR10A-7R-4S)

Data Transfer/Communications

BNC

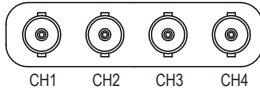

CH1: Master Connection (75 Ω)

Connectors on camera body

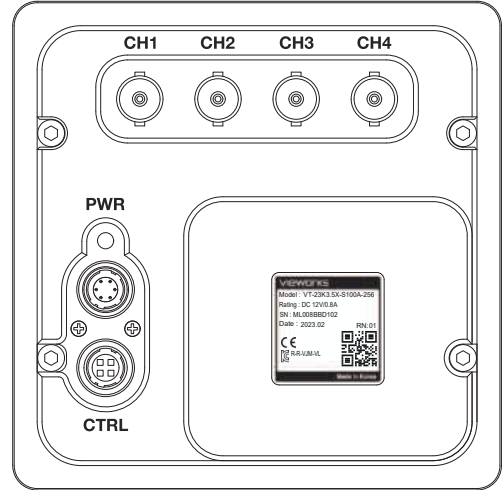

Ordering Scheme

VT-23K 3.5 X-S 100 A-256	
Series	Sensor Options
VT Series	A - Vieworks
Sensor Resolution	Max. TDI Stages
9K - 8912 pixels	128 - 128 stages
12K - 12480 pixels	256 - 256 stages
16K - 16384 pixels	
18K - 17824 pixels	
23K - 23360 pixels	
Pixel Size	Line Rate
3.5 - 3.5 μm	80 - 80 kHz / 94 kHz
5 - 5.0 μm	100 - 100 kHz
7 - 7.0 μm	120 - 125 kHz
	140 - 140 kHz
	160 - 160 kHz
	200 - 200 kHz
	250 - 250 kHz
Interface	Sensitivity
X - CoaXPress	S - Sensitivity