

VC-65MX2-M/C 71 I

65 Megapixel High Speed CMOS Digital Camera
with CoaXPress 2.0 Interface



The VC-65MX2-M/C 71 I, the latest model of the industrial proven VC series, is a new 65-megapixel CoaXPress camera and based on the CMOS global shutter image sensor technology (GMAX3265) from Gpixel. The VC-65MX2-M/C 71 I offers up to 71.1 frames per second at 9,344 × 7,000 resolution. The camera comes with the next generation CoaXPress 2.0 (CXP-12) interface delivering up to 50 Gigabits per second over four coaxial cables. These combinations of the CMOS sensor technology and CoaXPress 2.0 interface set a new standard for industrial, scientific and surveillance digital imaging applications. Equipped with the Viewworks' innovative technologies proved by world's top FPD manufacturers, the VC-65MX2-M/C 71 I camera offers not only highly uniformed images but also high-speed image processing capabilities. Featured with high-quality image uniformity and high-resolution, this camera is ideal for demanding applications such as FPD, PCB and semiconductor inspections.

VC-65MX2-M/C 71 I

65 Megapixel High Speed CMOS Digital Camera with CoaXPress 2.0 Interface

- VC-65MX2-M/C71 I (with a Fan)

Unit: mm

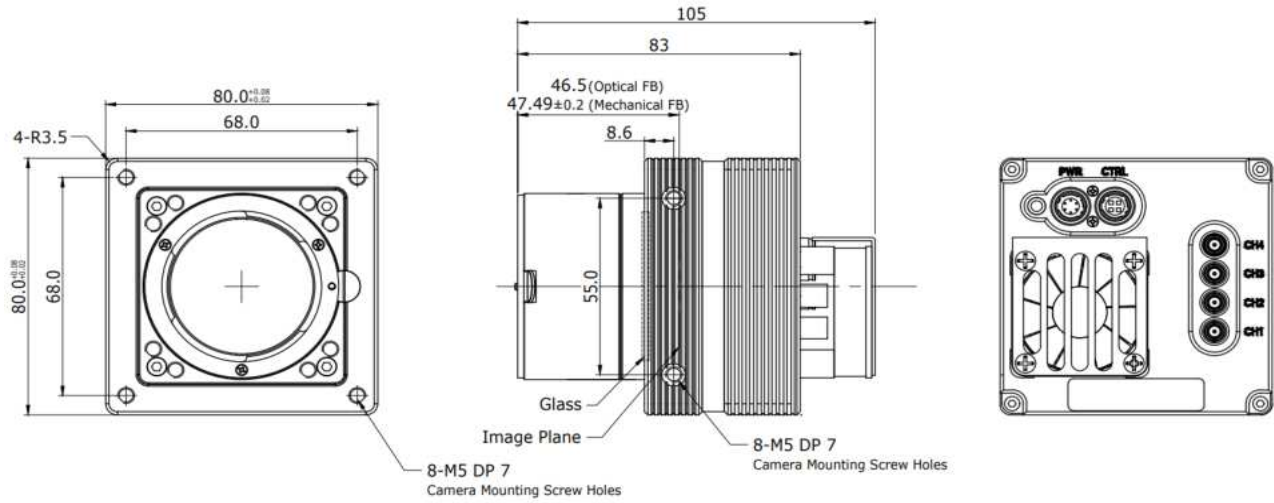

- VC-65MX2-M/C71 I (with Heatsink)

Unit: mm

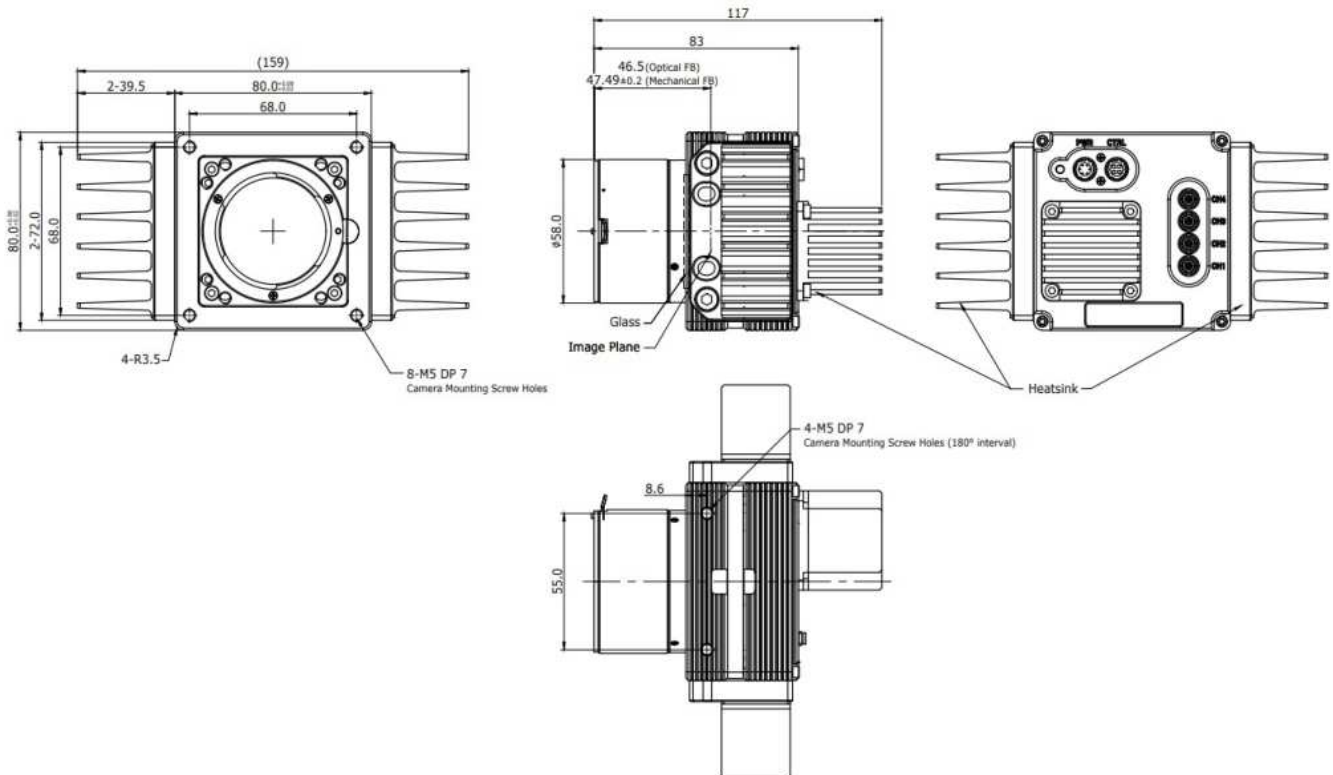

- High Speed 65 Megapixel CMOS Image Sensor
- CoaXPress 2.0 Interface up to 71.1 fps at 50 Gbps using 4 CH
- Global Shutter CMOS Technology
- DSNU and PRNU Correction
- Flat Field Correction
- Defective Pixel Correction
- Hot Pixel Correction
- GenICam Compatible – XML based Control
- Flat Panel Display Inspection
- Electronics Inspection
- Semiconductor Inspection
- Document / Film Scanning

Model		VC-65MX2-M/C 71 I
Resolution (H × V)		9,344 × 7,000
Sensor		Gpixel GMAX3265 – High Speed
Sensor Size (Diagonal)		29.9 mm × 22.4 mm (37.4 mm)
Sensor Type		High Speed CMOS Image Sensor
Pixel Size		3.2 μm × 3.2 μm
Interface		CXP-12 × 4
Max. Frame Rate	CXP-6 × 4	37.2 fps
	CXP-10 × 4	59.2 fps
	CXP-12 × 4	71.1 fps
Exposure Time (1 μs step)		12 μs – 60 s
Partial Scan (Max. Speed)		13888.8 fps at 4 Lines
Binning		×1, ×2, ×4 (Horizontal and Vertical Independent)
Pixel Data Format	Mono	Mono 8 / Mono 10
	Color	GB Bayer 8 / GB Bayer 10
Electronic Shutter		Global Shutter
Trigger Synchronization		Free-Run, Hardware Trigger, Software Trigger or CXP
External Trigger		3.3 V ~ 24.0 V, 10 mA, Logical Level Input, Optically Isolated
Software Trigger		Asynchronous, Programmable via Camera API
Dynamic Range		10bit: typical 60 dB (EMVA1288, Exposure: 5000μs)
Gain Control		1× ~ 32×
Black Level Control		0 ~ 63.75 LSB at 10 bit
Dimension / Weight		159 mm × 80 mm × 117 mm, 920 g (with F-mount)
Environmental Temperature		Operating: 0°C ~ 40°C, Storage: -40°C ~ 70°C
Camera Temperature		Camera Internal Temp: Max. 65°C / Camera Case Temp: Max: 55°C
Lens Mount		F-mount, Custom mount available upon request
Power	External	11 ~ 24 V DC
	Dissipation	Typ. 22.0 W, Max: 26W (Camera Internal Temp: 65°C)
	PoCXP	24 V DC, Minimum of two PoCXP cables required
Compliance		CE, FCC, KC
API SDK		Vieworks Imaging Solution 7.X

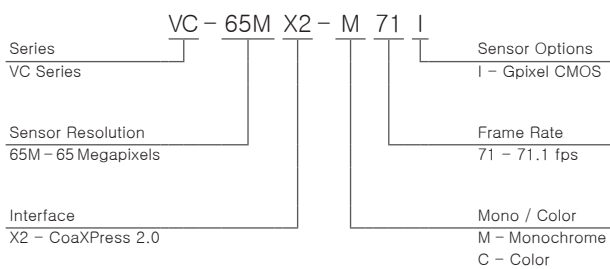
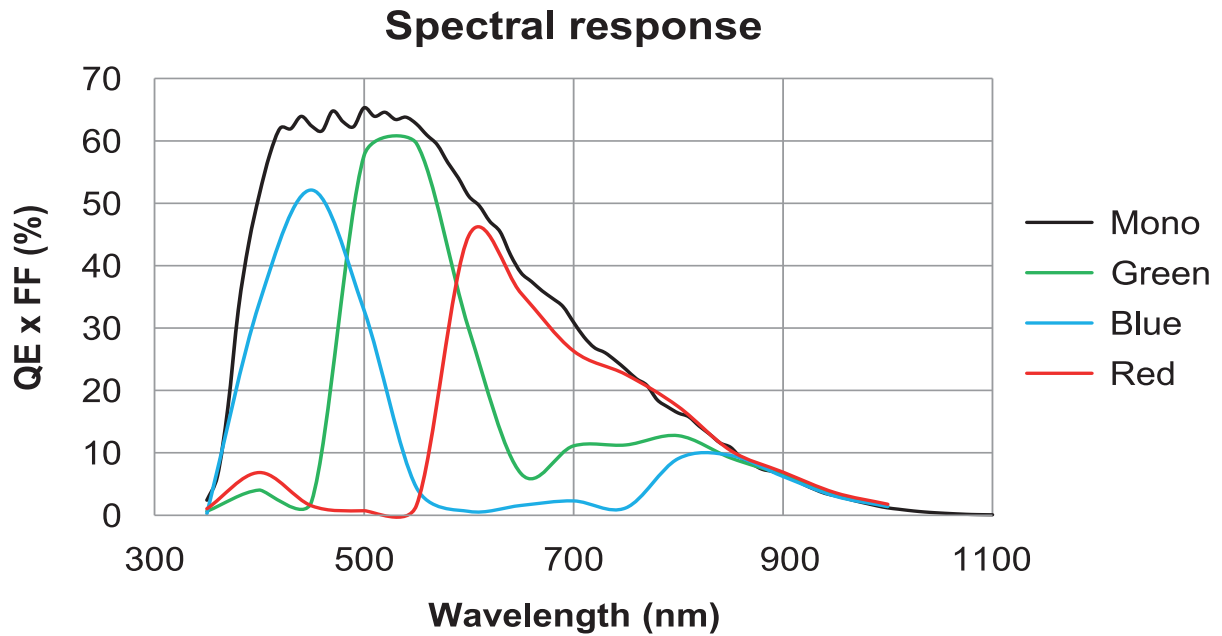

Power

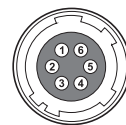

1, 2, 3: +12V DC
4, 5, 6: GND
(HR10A-7R-6PB)

Control

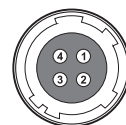

1: Trigger IN+
2: Trigger IN-
3: Strobe Out-(GND)
4: Strobe Out+
(HR10A-7R-4S)

Data Transfer / Communications

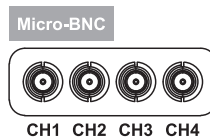

CH1: Master Connection
75 Ω, Micro-BNC (HD-BNC)

Connectors on camera body